

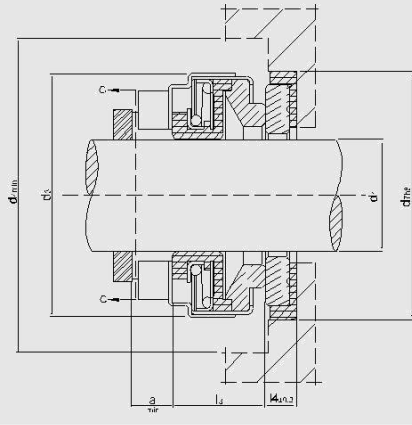

FA

### FA pozitif sürüş - Tip1



### FA pozitif sürüş - Tip2

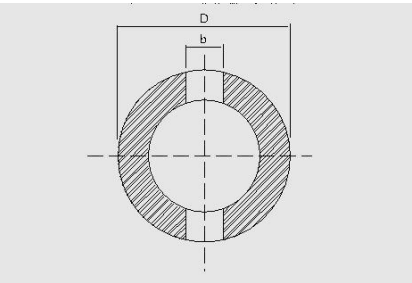
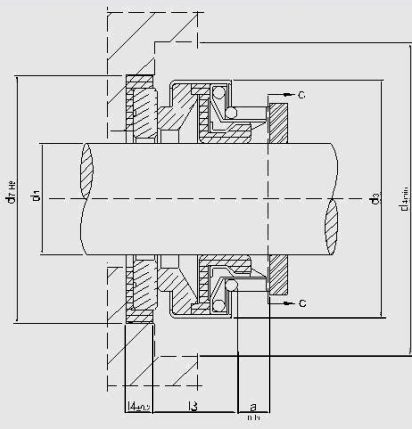

### FA

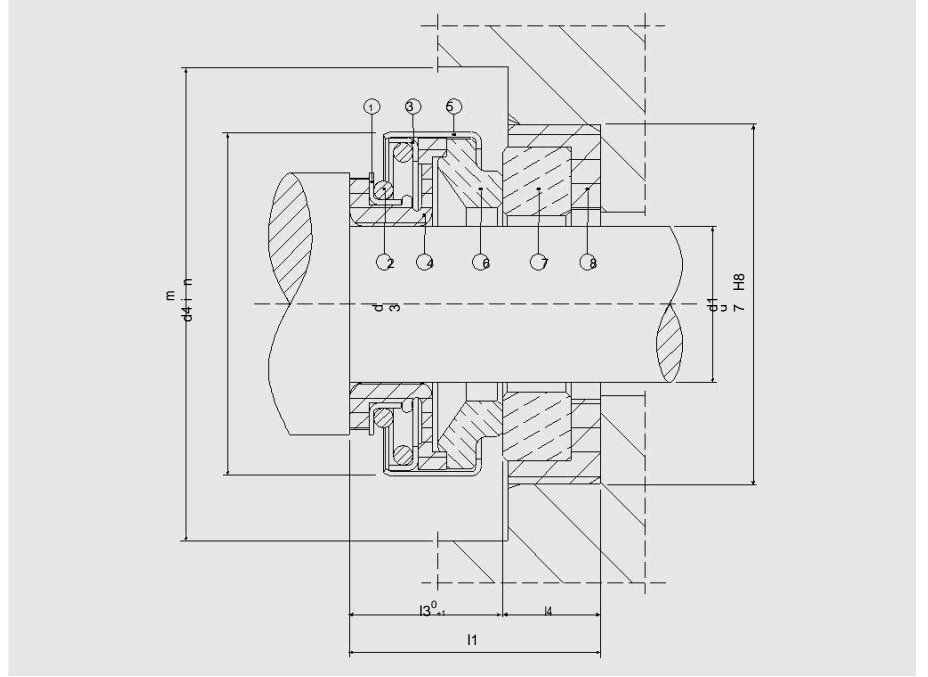

### Çalıştırma Sınırı

P	6 bar
V	12 m/s
T	-30 +200°C

### Standart Bileşenler



Açıklama	Bileşenler				
1 Kafa bileziği	Paslanmaz çelik	G	F	-	-
2 Sping	Paslanmaz çelik	G	F	-	-
3 Tespit segmanı	Paslanmaz çelik	G	F	-	-
4 conta	Kauçuk	P - P1 P3 - P4	E	V	-
5 Kutu	Paslanmaz Çelik	G	F	-	-
6 Kontak halkası	Çeşitli	B1 - B2	A	-	U - Q
7 kontra somun	Çeşitli	V	G - F1	U - Q	X
8 Gasket	Kauçuk	P - P1 P3 - P4	E	V	-

## FA

SINIF		d1	d3	I3	d4	d7	I4	I1	
6	18	8,5	6±0,1	18	8,5±0,5	24	22	4	12,5
8	18	8,5	8±0,1	18	8,5±0,5	24	22	4	12,5
8	18	11	8±0,1	18	11±0,5	24	22	4	15
8	24	11	8±0,1	24	11	28	26	5,5/8	16,5/19
9	24	11	9±0,1	24	11	28	26	5,5/8	16,5/19
10	24	11	10±0,1	24	11	28	26	5,5/8	16,5/19
11	24	11	11±0,1	24	11	28	26	5,5/8	16,5/19
12	24	13	12±0,1	24	13	28	26	5,5/8	18,5/21
13	24	13	13±0,1	24	13	28	26	5,5/8	18,5/21
12	32	13	12±0,1	32	13	36/40	29,5/38	8	21
14	28	12,8	14±0,1	28	12,8	36	29,5/38	7,5	20,5
14	32	13	14±0,1	32	13	36/40	29,5/38	8	21
15	32	13	15±0,1	32	13	36/40	29,5/38	8	21
16	32	13	16±0,1	32	13	36/40	29,5/38	8	21
14	35	13	14±0,1	35	13	40	29,5/38	8	21
15	35	13	15±0,1	35	13	40	29,5/38	8	21
16	35	13	16±0,1	35	13	40	29,5/38	8	21
16	39	13	16±0,1	39	13	45	42	8	21
17	39	13	17±0,1	39	13	45	42	8	21
18	39	13	18±0,1	39	13	45	42	8	21
19	39	13	19±0,1	39	13	45	42	8	21
20	39	13	20±0,1	39	13	45	42	8	21
20	42	13	20±0,1	42	13	50	45	10	23
22	42	13	22±0,1	42	13	50	45	10	23
24	47	14	24±0,1	47	14	60	50	10	24
25	42	14	25±0,1	42	14	50	45	10	24
25	47	14	25±0,1	47	14	60	50	10	24
28	54	15	28±0,1	54	15	68	57	10	25
30	54	15	30±0,1	54	15	68	57	10	25
32	54	15	32±0,1	54	15	68	57	10	25
35	60	16	35±0,1	60	16	72	63	10	26
38	65	18	38±0,1	65	18	72	68	12	30
40	65	18	40±0,1	65	18	72	68	12	30
45	70	20	45±0,1	70	20	80	73	12	32
50	85	23	50±0,1	85	23	92	88	15	38
55	85	23	55±0,1	85	23	92	88	15	38
60	105	30	60±0,1	105	30	115	110	15	45
70	105	32	70±0,1	105	32	115	110	15	47

Production on order

## FA pozitif sürüş

SINIF		d1	d3	d4	d7	I3	I4	D	a	b	
8	18	11	8±0,1	18	24	22	11±0,5	4	14	2,5	6
12	32	12,8	12±0,1	32	35	38	12,8+0,5	8	24	4	10
14*	32	12,8	14±0,1	32	38	38	12,8+0,5	8	28	4	10
15	32	12,8	15±0,1	32	38	38	12,8+0,5	8	28	4	10
16*	32	12,8	16±0,1	32	38	38	12,8+0,7	8	28	4	10
16*	39	12,8	16±0,1	39	42	42	12,8+0,7	8	32	4	10
17	39	12,8	17±0,1	39	42	42	12,8+0,7	8	32	4	10
18	39	12,8	18±0,1	39	42	42	12,8+0,7	8	32	4	10
19*	39	12,8	19±0,1	39	42	42	12,8+0,7	8	32	4	12
20	39	12,8	20±0,1	39	42	42	12,8+0,7	6	32	4	12
24*	48	13,5	24±0,1	48	51	50	13,5+1	10	40	6	12
25	48	13,5	25±0,1	48	51	50	13,5+1	10	40	6	12
28	55	15	28±0,1	55	58	57	15+1	10	45	6	12
30	55	15	30±0,1	55	58	57	15+1	10	45	6	12
32	55	15	32±0,1	55	58	57	15+1	10	47	6	12
35	61	16	35±0,1	61	64	63	16+1	10	52	7	12

Type 2

